

Minutes from WNPSC 05/08/00

Attendees:

Anna Miller - Bellsouth Cellular
Brian Egbert - Sprint PCS
Maggie Lee - Illuminet
Steve Addicks – World Com
Anne Cummins - AT&T Wireless
Richard Bell - GTE
Dunice Harrell - Bellsouth Cellular Corp
Jim Grasser – Ameritech Cellular
Marcel Champagne - NeuStar

1.) Introduction and agenda approval

2.) NPAC notification process

ACTION ITEM: Anna will find out who in the CCB and Wireless Bureau should be contacted.

ACTION ITEM: Anna, Anne and Brian will have a conference call next week with John Hoffman, NANC Chair, to socialize the concept and ask for help with the CCB and the Wireless Bureau to obtain a list of wireless carriers. Once the list is prepared, Neustar will send the letter out. The letter will include cutoff dates for signing up for certification testing and the need to decide which solution the carrier is going to use - service bureau or provide their own SOA/LSMS. Having the SOA/LSMS certified is a pre-requisite to Intercarrier (SP to SP) testing.

The timeline is as follows:

May 15 – 19: Anna, Anne and Brian will have a conference call with John Hoffman
May 15 – 19: Anna will get names of contacts at the CCB and Wireless Bureau
May 19 - June 9th: Anna, Anne, John H., and Brian will have a conference call with CCB and Wireless Bureau, requesting a list of wireless carrier contacts and discussing other possible FCC communications (News Release, FCC or NANC web site, etc.)
May 23: Brian will present concept to the NANC
June 12: Marcell will have a draft letter for the WNPSC to review and finalize for presentation at the June NANC meeting
June 20: Present letter to NANC for discussion and approval
Sept. 15: Receive list of wireless carriers from CCB and Wireless Bureau
Sept 15 - Oct 15: Neustar will develop wireless carrier distribution list
Oct 15: First letter goes out
Dec 1: Second letter goes out with warning that there are 2-1/2 months left to sign up
Jan 15: Third letter with a warning that carriers have 30 days to sign up
Feb 16: Cut off for signing up
May 1 - Aug 31: NPAC Certification testing

3.) CIGRR issue

Discussed a contribution that will be taken to CIGRR this week that asks for the immediate removal of the block on marking wireless codes as portable. This prevents service providers using fixed wireless applications from participating in LNP today, and will prevent CMRS from having portable NXXs for LNP testing and implementation until removed.

ACTION ITEM: The WNPSC members are requested to contract their CIGRR representatives to support this contribution.

4.) Wireless Reseller Process

Agreement reached that PIM 1 should include wireless. Brian understood that Ops West thought wireless should have their own flows. Jim said that we could either update the proposed wireline diagrams to include wireless or we can submit wireless only. Jim said that it was important that wireless did not go to OBF empty-handed. We need to go to OBF with our recommendations.

The WNPSC agreed to the following wireless to wireless reseller process flows. These were presented for reference to the LNPAWG. For LNPAWG discussion purposes, interspecies reseller flows were developed. See flow diagrams below.

ACTION ITEM: The WNPSC will discuss at the June meeting the interspecies reseller flows. Then we will take a WNPSC contribution to the LNPAWG on this PIM in July and then submit the issue into OBF in August or wait until November. Dunice pointed out that the outcome of this contribution will affect the ICC requirements and therefore it is important for us to get the contribution to OBF in August.

Wireless to wireless

Assumption: For a complex port it is assumed that coordination is co

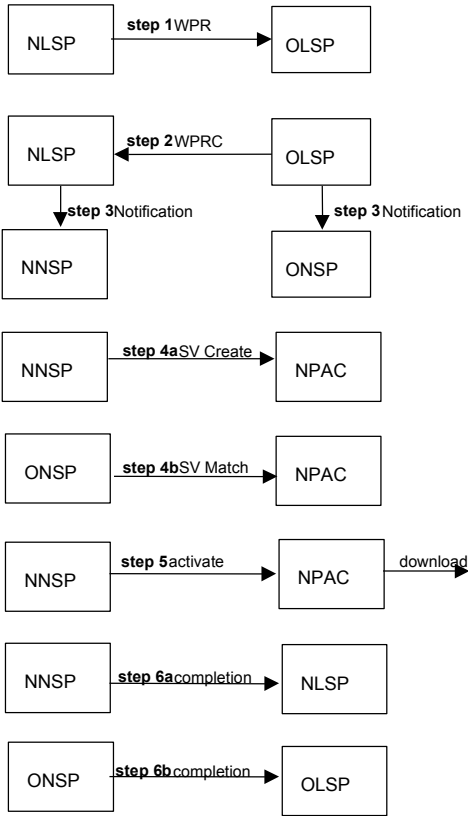

Wireline to wireless

Assumption: For a complex port it is assumed that coordination is co

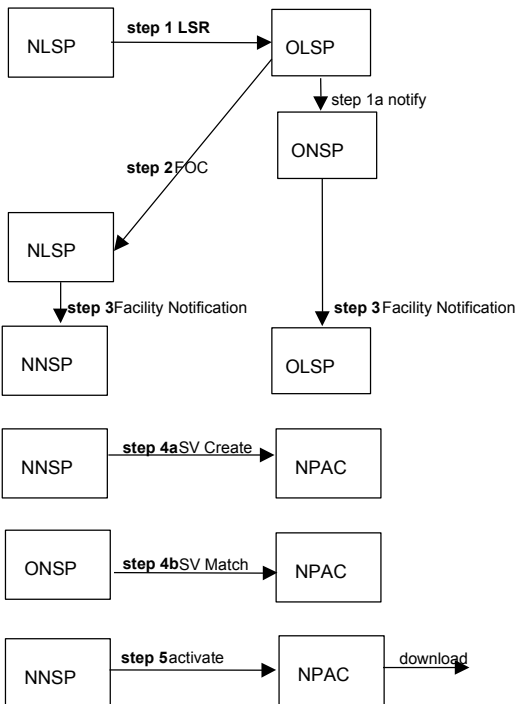

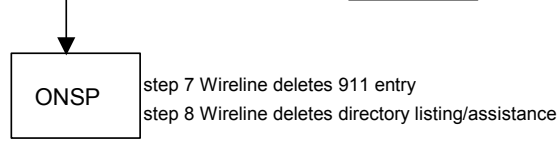
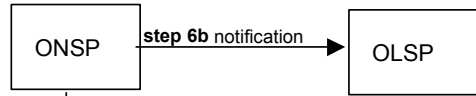
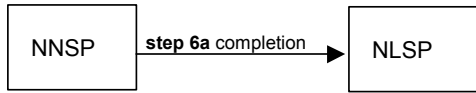

Wireless to wireline

Assumption: For a complex port it is assumed that coordination is cc

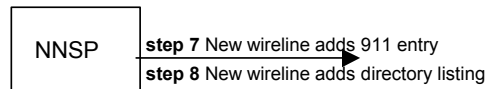
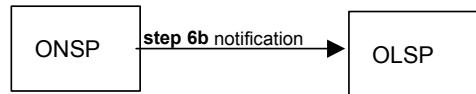
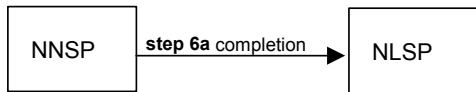
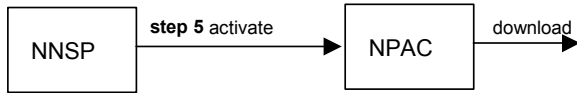
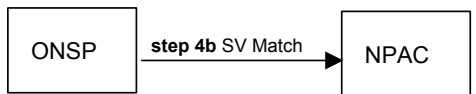
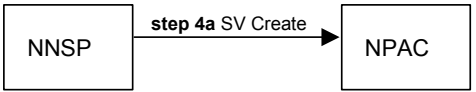
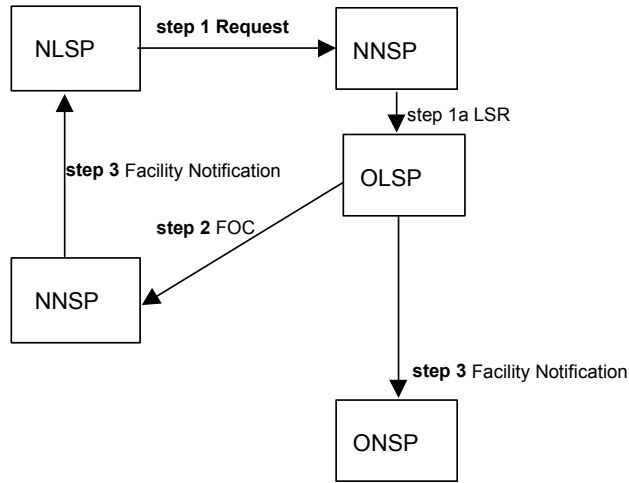

5.) Updates

- **JIP Liaison**
- **Regional Operational Teams** - No wireless issues
- **Inter-carrier Communication Process** - CTIA Board to vote week of June 11th
- **Test Plan** - Anne will ask Paul Gerth of AWS if he will take the chair temporarily to set up a conference call to set the dates for a three day lock down meeting, establish who will be responsible for what sections of draft and lead the section's review. Anna and Brian will discuss at the next Ops Meeting the intent and the need for wireless leadership and participation.

6.) New Business - How will wireless carriers handle resellers wanting to port all of their customers to another facility based provider. From a business standpoint, as LERG code holders, we should keep the unassigned numbers so that we can reassign them our customers, unless we want to port the full block. This needs to be addressed in the 99-200 proceeding.

7.) Wireless Report - The primary goal of the June meeting will be to complete the Wireless Number Portability Report. The WNPSC meeting will start promptly at 8:30AM on Monday, June 12th, addressing the NPAC testing notification letter and updates. The rest of the meeting will be dedicated to the report, including a Thursday afternoon session to complete the Executive Summary.

8.) NEXT MEETING: 8:30 to 5 Monday, 8:30 to 12 noon, Thursday afternoon 1:00 to 5:00.

Meeting Adjourned